

# EXACTECH | SHOULDER

Operative Technique Addendum



**equinox<sup>®</sup>**

Augmented Reverse  
Glenoid Implants for use  
with Ergo<sup>®</sup> Instruments



## POSTERIOR AUGMENT GLENOID PLATE OVERVIEW TECHNIQUE



A

Drill Hole for Pilot Reamer



B

Ream the Glenoid at Eight-Degrees



C

Drill Central Hole to Establish Axis of Cage

## SUPERIOR AUGMENT GLENOID PLATE OVERVIEW TECHNIQUE



A

Establish Central Axis of the Scapular and Drill Hole for Pilot Reamer



B

Ream the Glenoid at 10 Degrees



C

Drill Central Hole to Establish Axis of Cage

## SUPERIOR/POSTERIOR AUGMENT PLATE OVERVIEW TECHNIQUE

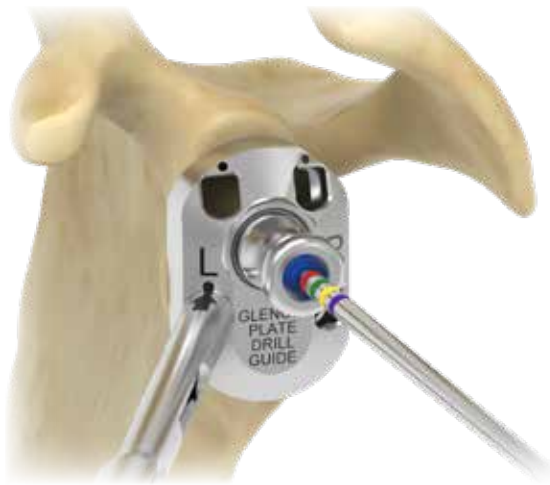

A

Drill Hole for Pilot Reamer



B

Ream the Glenoid at 13 Degrees



C

Drill Central Hole to Establish Axis of Cage

## DETAILED OPERATIVE TECHNIQUE

### REVERSE SHOULDER POSTERIOR AUGMENT GLENOID PLATE TECHNIQUE

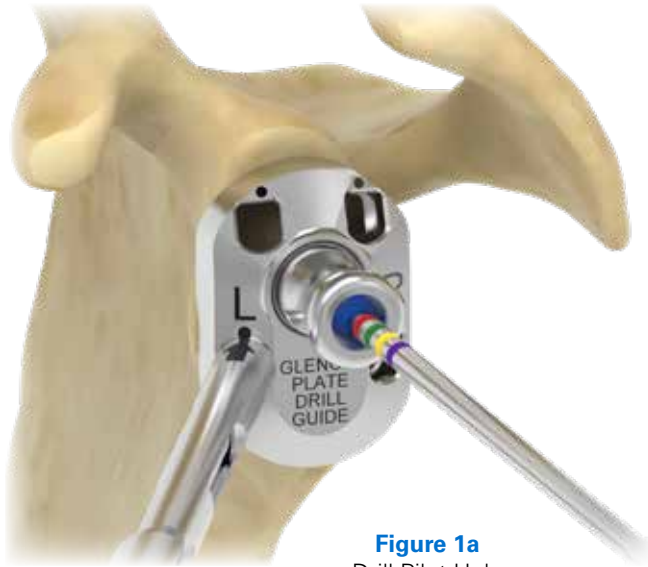

**Figure 1a**  
Drill Pilot Hole

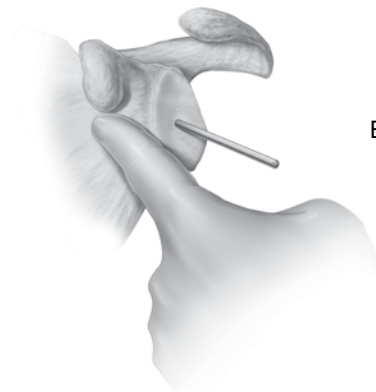

**Figure 1b**  
Establish Central Axis  
of the Scapula

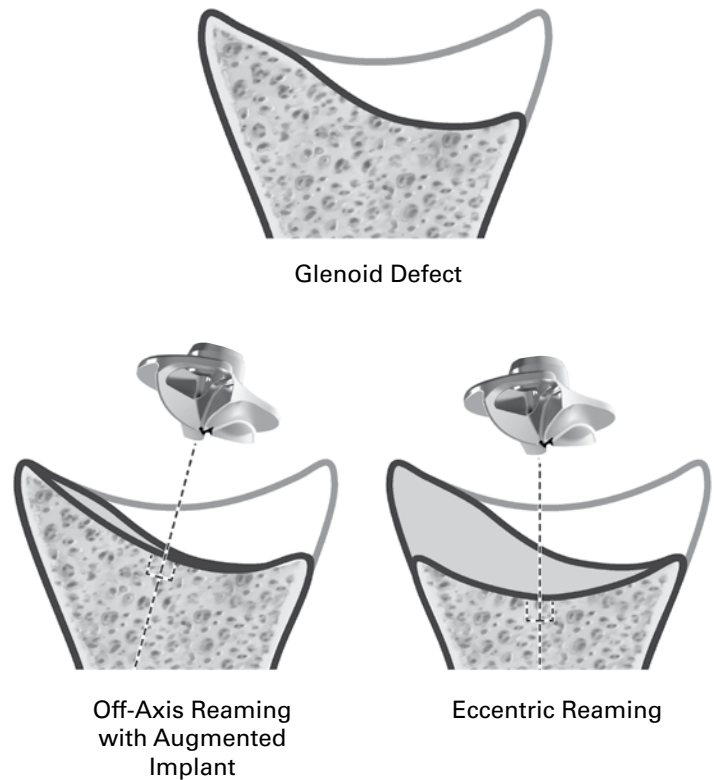

**Figure 2**  
Bone Conservation

The reverse shoulder **Posterior Augment Glenoid Plate** is designed to minimize the removal of anterior cortical bone when reaming a posteriorly worn glenoid in order to correct its version.

Assuming the patient has posterior wear, an irreparable rotator cuff tear and the surgeon wants to correct the glenoid back to neutral version:

- If glenoid retroversion is less than six degrees; use the **standard Glenoid Plate** and eccentrically ream as needed.
- If glenoid retroversion is between six degrees and 11 degrees, use the Posterior Augment Glenoid Plate.
- If glenoid retroversion is between 12 degrees and 18 degrees; use the Posterior Augment Glenoid Plate and eccentrically ream if there is sufficient bone stock.
- If the surgeon deems that there is insufficient glenoid bone stock to achieve fixation, bone graft and use the **+10mm**

**Extended Cage Glenoid Plate** and/or use the **Expanded Glenospheres**.

Using the 3.2mm drill bit, drill a pilot hole in the center of the glenoid at an angle consistent with the augmented implant's backside angular offset. The surgeon may use two methods to achieve this:

- 1) a standard reverse glenoid baseplate drill guide (321-52-33) and a K-wire adapter (315-51-10) to assist in targeting the axis perpendicular to the worn glenoid's surface. It is suggested that the surgeon drill to at least the orange depth marking when making the pilot tip hole (*Figure 1*).
- 2) The surgeon may also establish a neutral axis via Matsen's point (*Figure 1b*) and then ream at their own discretion based off of this neutral axis. For both methods, Exactech offers preoperative planning to better prepare for surgery.



**Figure 3**  
Ream the Glenoid at 8  
Degrees



**Figure 4**  
Drill Central Hole to Establish  
Axis of Cage

**Note:** Eight degrees is used to off-axis ream the glenoid in order to correct for the posterior glenoid defect as this corresponds to the build-up of the Posterior Augment Glenoid Plate.

Note: Off-axis reaming removes less bone than would occur ordinarily during eccentric reaming to correct the same defect (i.e., reaming down the high side). For example, compare the bone removed between off-axis reaming and eccentric reaming of a defect (Figure 2).

Ream the glenoid at 8 Degrees using the appropriately sized Modular Reverse Reamer and the PilotTip Glenoid Reamer Driver (Figure 3).

Drill the hole for the Posterior Augment Glenoid Plate cage (e.g., central axis of the scapula) using the reverse shoulder **8° Posterior Glenoid Plate Drill Guide**, the Cannulated Glenoid Reamer Driver, and the **Gold Modular Center Peg Drill** (Figure 4).

Impact the Posterior Augment Glenoid Plate and continue with the existing **Ergo Primary/Reverse Operative Technique (Lit#00-0000121)**.

**Note:** Avoid applying a bending force to the pilot tip reamer or using the reamer to retract the humeral head as this may cause fracture of the pilot tip.

## DETAILED OPERATIVE TECHNIQUE

### REVERSE SHOULDER SUPERIOR AUGMENT GLENOID PLATE TECHNIQUE

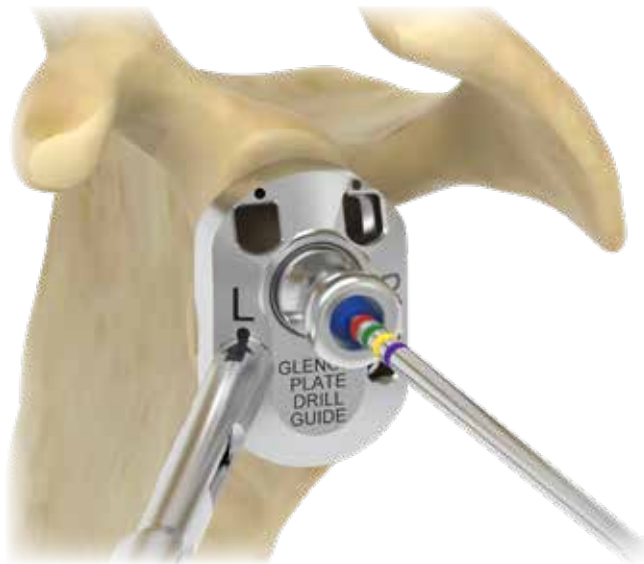

**Figure 5a**  
Drill Pilot Hole

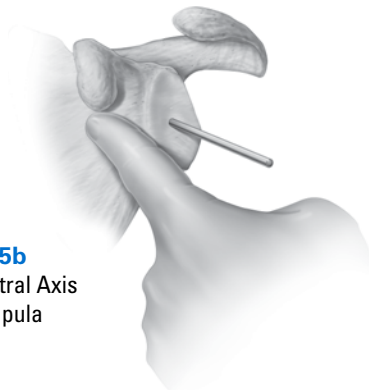

**Figure 5b**  
Establish Central Axis  
of the Scapula

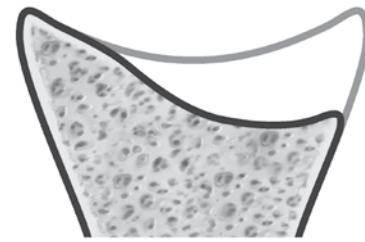

Glenoid Defect

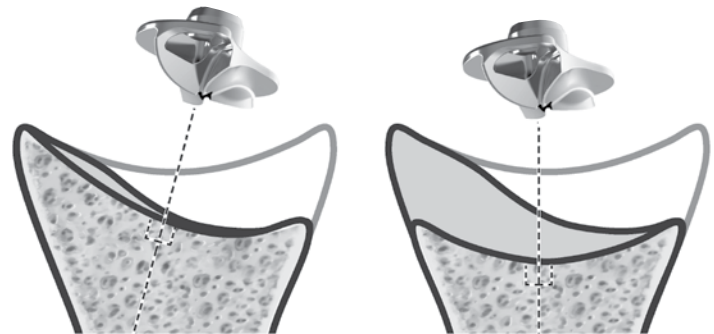

Off-Axis Reaming  
with Augmented  
Implant

Eccentric Reaming

**Figure 6**  
Bone Conservation

#### REVERSE SHOULDER SUPERIOR AUGMENT GLENOID PLATE TECHNIQUE

The reverse shoulder **Superior Augment Glenoid Plate** is designed to minimize the removal of the inferior cortical bone when reaming a superiorly worn glenoid in order to correct its inclination.

Assuming the patient has superior wear, an irreparable rotator cuff tear and the surgeon wants to correct the glenoid back to neutral inclination:

- If the glenoid is superiorly worn less than seven degrees, use the standard Glenoid Plate and eccentrically ream as needed.
- If the glenoid is superiorly worn between seven degrees and 13 degrees; use the Superior Augment Glenoid Plate.
- If the glenoid is superiorly worn between 14 degrees and 18 degrees; use the Superior Augment Glenoid Plate and eccentrically ream if there is sufficient bone stock.

- If the surgeon deems that there is insufficient glenoid bone stock to achieve fixation, bone graft and use the **+10mm Extended Cage Glenoid Plate** and/or use the **Expanded Glenspheres**.

Using the 3.2mm drill bit, drill a pilot hole in the center of the glenoid at an angle consistent with the augmented implant's backside angular offset. The surgeon may use two methods to achieve this:

- 1) a standard reverse glenoid baseplate drill guide (321-52-33) and a K-wire adapter (315-51-10) to assist in targeting the axis perpendicular to the worn glenoid's surface. It is suggested that the surgeon drill to at least the orange depth marking when making the pilot tip hole (*Figure 5*).
- 2) The surgeon may also establish a neutral axis via Matsen's point (*Figure 1b*) and then ream at their own discretion based off of this neutral axis. For both methods, Exactech offers preoperative planning to better prepare for surgery.



**Figure 7**  
Ream the Glenoid at  
10 Degrees



**Figure 8**  
Drill Center Hole to Establish  
Axis of Cage

**Note:** 10 degrees is used to off-axis ream the glenoid in order to correct for the superior glenoid defect as this corresponds to the build-up of the Superior Augment Glenoid Plate.

**Note:** Off-axis reaming removes less bone than would occur ordinarily during eccentric reaming to correct the same defect (i.e., reaming down the high side). For example, compare the bone removed between off-axis reaming and eccentric reaming of a defect (Figure 6).

Ream the glenoid at 10 degrees using the appropriately sized Modular Reverse Reamer and the Pilot Tip Glenoid Reamer Driver (Figure 7).

Drill the hole for the Superior Augment Glenoid Plate cage (e.g., central axis of the scapula) using the reverse shoulder 10° Superior Glenoid Plate Drill Guide, the Cannulated Glenoid Reamer Driver, and the Gold Modular Central Peg Drill (Figure 8).

Implant the Superior Augment Glenoid Plate and continue with existing **Ergo Primary/Reverse Operative Technique (Lit#00-0000121)**.

**Note:** Avoid applying a bending force to the pilot tip reamer or using the reamer to retract the humeral head as this may

## DETAILED OPERATIVE TECHNIQUE

### REVERSE SHOULDER SUPERIOR/POSTERIOR AUGMENT GLENOID PLATE TECHNIQUE



**Figure 9a**  
Drill Pilot Hole

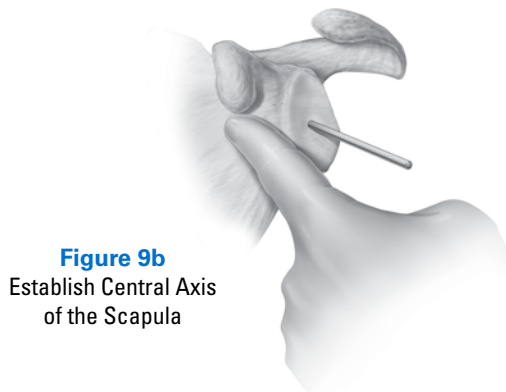

**Figure 9b**  
Establish Central Axis  
of the Scapula

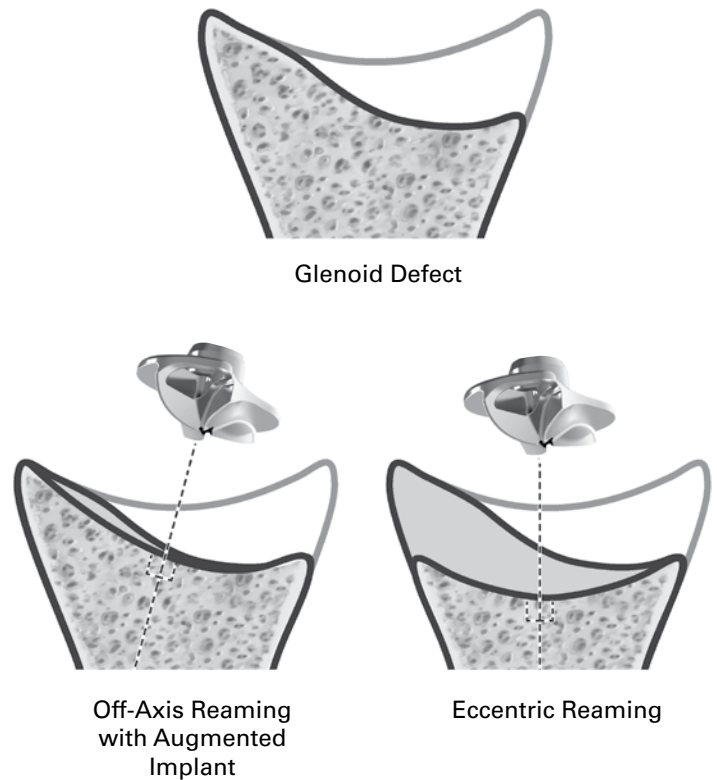

**Figure 10**  
Bone Conservation

cause fracture of the pilot tip.

#### REVERSE SHOULDER SUPERIOR/POSTERIOR AUGMENT GLENOID PLATE TECHNIQUE

The reverse shoulder **Superior/Posterior Augment Glenoid Plate** is designed to minimize the removal of the inferior cortical bone and anterior cortical bone when reaming a superiorly and posteriorly worn glenoid in order to correct its inclination and version.

Assuming the patient has superior and posterior wear, an irreparable rotator cuff tear and the surgeon wants to correct the glenoid back to neutral inclination and version:

- If glenoid wear is less than six degrees in both superior and retroversion planes, use the standard glenoid plate (320-15-01) and eccentrically ream as needed.
- If glenoid is superiorly worn between seven degrees and 13 degrees, and glenoid retroversion is between six degrees

and 11 degrees, use the Superior/Posterior Augment Plate.

- If the glenoid is superiorly worn between 14 degrees and 18 degrees and retroversion is between 12 degrees and 18 degrees, use the Superior/Posterior Augment Plate and eccentrically ream if there is sufficient bone stock.
- If the surgeon deems that there is insufficient glenoid bone stock to achieve fixation, bone graft and use the **+10mm Extended Cage Glenoid Plate** and/or the **Expanded Glensphere**.

Using the 3.2mm drill bit, drill a pilot hole in the center of the glenoid at an angle consistent with the augmented implant's backside angular offset. The surgeon may use two methods to achieve this:

- 1) a standard reverse glenoid baseplate drill guide (321-52-33) and a K-wire adapter (315-51-10) to assist in targeting



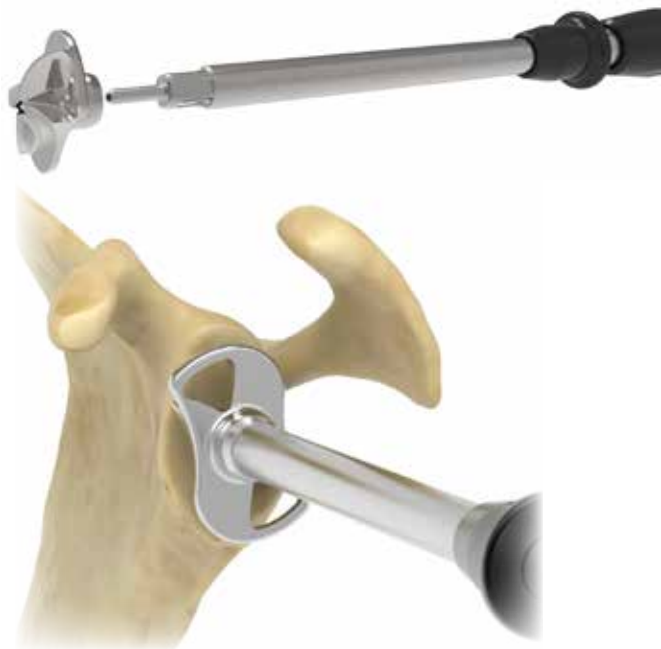

**Figure 11**

Ream the Glenoid at 13 degrees



**Figure 12**

Drill Center Hole to Establish Axis of Cage

the axis perpendicular to the worn glenoid's surface. It is suggested that the surgeon drill to at least the orange depth marking when making the pilot tip hole (Figure 9).

2) The surgeon may also establish a neutral axis via Matsen's point (Figure 1b) and then ream at their own discretion based off of this neutral axis. For both methods, Exactech offers preoperative planning to better prepare for surgery.

**Note:** 13 degrees is used to off-axis ream the glenoid in order to correct for the superior-posterior glenoid defect as this corresponds to the build-up of the Superior/Posterior Augment Glenoid Plate.

**Note:** Off-axis reaming removes less bone than would occur ordinarily during eccentric reaming to correct the same defect (i.e. reaming down the high side). For example, compare the bone removed between off-axis reaming and eccentric reaming of a defect (Figure 10).

Ream the glenoid at 13 degrees using the appropriately sized Modular Reverse Reamer and the Pilot Tip Glenoid Reamer Driver (Figure 11).

Drill the hole for the Superior/Posterior Augment Glenoid Plate cage over the central axis of the scapula using the reverse shoulder Posterior/Superior Glenoid Plate Drill Guide, the Cannulated Glenoid Reamer Driver, and the Rose Gold Extended Drill Bit, Pilot Tip (315-52-68) (Figure 12).

Implant the Superior/Posterior Augment Glenoid Plate and continue with existing **Ergo Primary/Reverse Operative Technique (Lit#00-0000121)**.

**Note:** Avoid applying a bending force to the pilot tip reamer or using the reamer to retract the humeral head as this may cause fracture of the pilot tip.

**Note:** The Extended drill bit will also be used when preparing the glenoid for the Extended Cage Implant.

## EQUINOXE IMPLANTS

Catalog No.	Part Description
320-02-38	38mm Expanded Glenosphere, +4mm lateral offset
320-02-42	42mm Expanded Glenosphere, +4mm lateral offset
320-15-01	Standard Glenoid Plate
320-15-02	Superior Augment Glenoid Plate, 10 Degrees
320-15-03	Posterior Augment Glenoid Plate, Eight Degrees, Left
320-15-04	Posterior Augment Glenoid Plate, Eight Degrees, Right
320-15-06	Extended Cage Glenoid Plate, +10mm
320-15-07	Superior/Posterior Augment Reverse Glenoid Plate, Left
320-15-08	Superior/Posterior Augment Reverse Glenoid Plate, Right



## EQUINOXE INSTRUMENTS

### OPT-311EAUG Equinoxe Ergo Anatomic Augment Kit

315-52-68	Extended Cage Drill, Pilot Tip
321-17-44	10° Superior Glenoid Plate Drill Guide
321-17-42	8° Posterior Glenoid Plate Drill Guide, L
321-17-43	8° Posterior Glenoid Plate Drill Guide, R
321-17-45	Posterior/Superior Glenoid Plate Drill Guide, L
321-17-46	Posterior/Superior Glenoid Plate Drill Guide, R



## INSTRUMENT LISTING

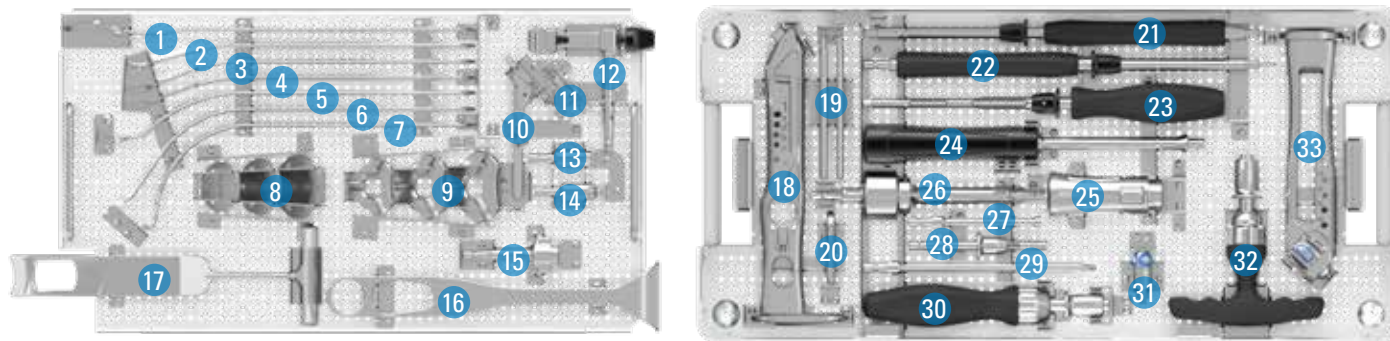

**EQUINOXE ERGO CORE INSTRUMENT TRAY (KIT-311X)**

1	Darrach Retractor	317-11-03
2	Small Forked Retractor	317-21-01
3	Hohmann Retractor	317-11-06
4	Hohmann Retractor	317-11-06
5	Wolfe Retractor	317-11-08
6	Dual Point Glenoid Retractor	317-11-04
7	Humeral Head Retractor	317-11-02
8	Small Humeral Protector	301-08-21
8	Medium Humeral Protector	301-08-41
8	Large Humeral Protector	301-08-61
9	Calcar Planer Blade 44mm	301-09-44
9	Calcar Planer Blade 50mm	301-09-50
9	Calcar Planer Blade 56mm	301-09-56
10	132.5 Degree Osteotomy Guide	311-11-13
11	IM Resection Guide	311-11-14
12	IM Guide Boom	311-11-11
13	Calcar Planer Adapter - Female Broach	301-09-01
14	Calcar Planer Adapter - Stem	301-09-02
15	Calcar Planer Body	301-09-00
16	Deltoid Retractor	317-21-06
17	Klimo Fukuda Retractor	317-21-05
18	EQII Broach Handle	301-05-02
19	Version Rod	301-05-20
20	Broach Collar	301-05-03
21	Cannulated Glenoid Reamer Driver	315-50-12
22	Pilot Tip Glenoid Reamer Driver	315-50-11
23	Modular Glenoid Guide Handle	315-52-11
24	Modular Impactor Handle	321-09-05*
25	Modular Counter Torque Handle	301-16-36
26	Geared Torque Screw Driver	321-16-69
27	Torque Defining Screw Removal Instrument	301-16-10
28	Glenoid Plate Coring Reamer	321-09-10
29	Hex Screw Driver 3.5mm	321-19-08
30	Non-Ratcheting Handle	301-09-90
31	Stem Extraction Tool	301-09-12
32	Ratcheting T-Handle	301-09-30
33	EQII Stem Inserter	301-09-20

\*The Impactor Handle (321-07-05) can be used as a substitute as needed.

## INSTRUMENT LISTING

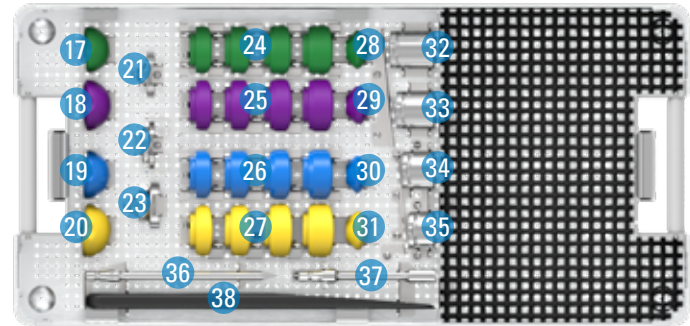
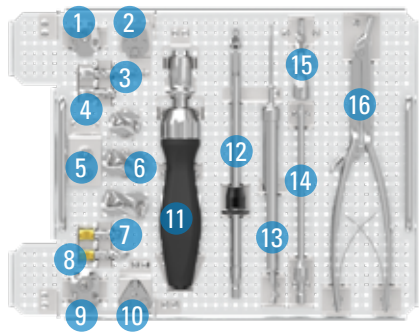

### EQUINOXE ERGO rTSA HUM/GLEN INSTRUMENT TRAY (KIT-321T)

1	Drill guide, Small Glenoid Plate	321-35-20
2	Inserter, Small Glenoid Plate	321-35-23
3	Small Reverse Modular Pilot Tip Drill	315-52-60
4	Small Reverse Modular Cannulated Drill	315-52-66
5	K-wire adapter (2 Kits)	315-51-10
6	Modular Reverse Reamer Starter	321-50-01
6	Modular Reverse Reamer 38mm	321-50-38
6	Modular Reverse Reamer 42mm	321-50-42
7	Modular Cannulated Central Peg Drill (2 Kits)	315-52-65
8	Modular Central Peg Drill (2 Kits)	315-52-64
9	Reverse Glenoid Baseplate Drill Guide	321-52-33
10	Glenoid Baseplate Impactor/Inserter	321-19-14
11	Ratcheting Screw Driver Handle	301-09-80
12	Adjustable Angle Drill Guide	321-19-05
13	Glenoid Screw Depth Gage	321-19-09
14	Tapered Glenosphere Inserter	321-01-57
15	Klimo Glenosphere Inserter	321-01-51
16	Glenosphere Inserter	321-01-52
17	Small Reverse Glenosphere Trial, 36mm*	321-31-36
18	Small Reverse Glenosphere Trial, 40mm*	321-31-40
19	EQ 38mm Glenosphere Trial	321-06-38
20	EQ 42mm Glenosphere Trial	321-06-42
21	EQ Humeral Tray Trial +0	321-14-00
22	EQ Humeral Tray Trial +5mm	321-14-05
23	EQ Humeral Tray Trial +10mm	321-14-10
24	Small Reverse Humeral Liner Trial, 36mm, +0*	321-36-00
24	Small Reverse Humeral Liner Trial, 36mm, +2.5*	321-36-03
24	Small Reverse Humeral Liner Trial, 36mm, +0, Constrained*	321-36-10
24	Small Reverse Humeral Liner Trial, 36mm, +2.5, Constrained*	321-36-13
25	Small Reverse Humeral Liner Trial, 40mm, +0*	321-40-00
25	Small Reverse Humeral Liner Trial, 40mm, +2.5*	321-40-03
25	Small Reverse Humeral Liner Trial, 40mm, +0, Constrained*	321-40-10
25	Small Reverse Humeral Liner Trial, 40mm, +2.5, Constrained*	321-40-13
26	38mm Humeral Liner Trial +0	321-38-00
26	38mm Humeral Liner Trial +2.5	321-38-03
26	38mm Humeral Liner Trial Constrained +0	321-38-10
26	38mm Humeral Liner Trial Constrained +2.5	321-38-13
27	42mm Humeral Liner Trial +0	321-42-00
27	42mm Humeral Liner Trial +2.5	321-42-03
27	42mm Humeral Liner Trial Constrained +0	321-42-10
27	42mm Humeral Liner Trial Constrained +2.5	321-42-13
28	Humeral Liner Impactor Tip, 36mm*	321-09-36
29	Humeral Liner Impactor Tip, 40mm*	321-09-40
30	Humeral Liner Impactor Tip 38mm	321-09-38
31	Humeral Liner Impactor Tip 42mm	321-09-42
32	Reverse Counter Torque +0 tip	321-16-00
33	Reverse Counter Torque +5 tip	321-16-05
34	Reverse Counter Torque +10 Tip	321-16-10
35	Reverse Counter Torque +15 Tip	321-16-15
36	Humeral Liner Removal Tool	321-19-11
37	rTSA Screw Starter Tool	321-16-06
38	Shoehorn/Reduction Tool	321-19-10

\*Small Reverse Glenosphere Trial, Humeral Liner Trial, and Humeral Liner Impactor Tip are not yet included in Kit-321T

POSTERIOR AUGMENT GLENOID PLATE

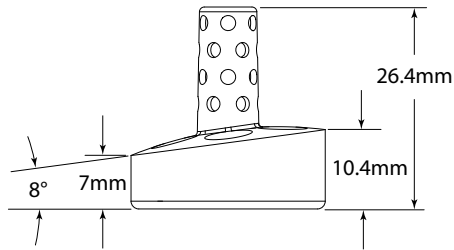

SUPERIOR AUGMENT GLENOID PLATE

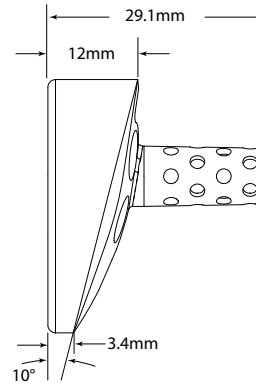

EXTENDED CAGE GLENOID PLATE, +10MM

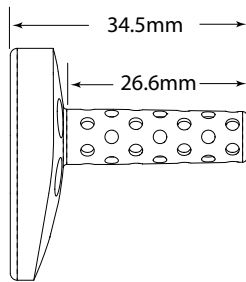

STANDARD CAGE GLENOID PLATE

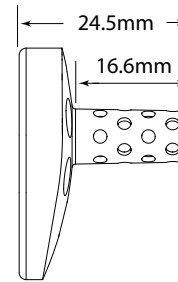

SUPERIOR/POSTERIOR AUGMENT GLENOID BASEPLATE

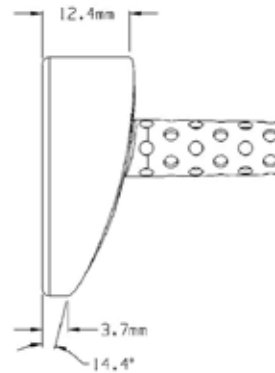
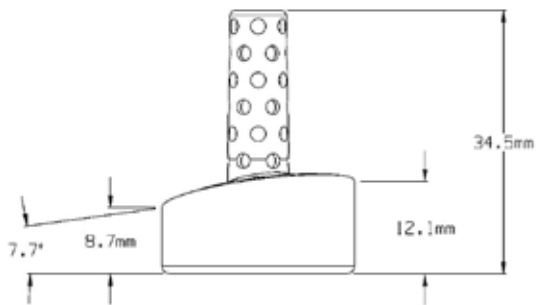

GLENOSPHERES

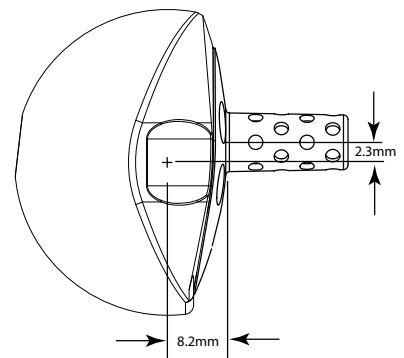
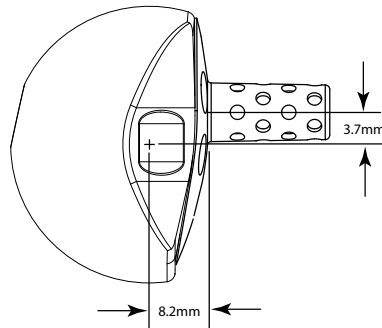
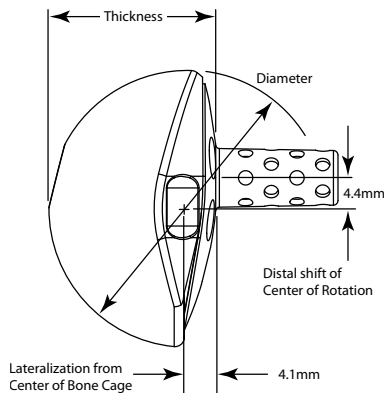

STANDARD GLENSPHERE

38MM EXPANDED GLENSPHERE

42MM EXPANDED GLENSPHERE

Exactech is proud to have offices and distributors around the globe. For more information about Exactech products available in your country, please visit [www.exac.com](http://www.exac.com)

---

For additional device information, refer to the Exactech Shoulder System—Instructions for Use for information including, but not limited to, a device description, indications, contraindications, precautions and warnings. For further product information, please contact Customer Service, Exactech, Inc., 2320 NW 66th Court, Gainesville, Florida 32653-1630, USA. (352) 377-1140, (800) 392-2832 or FAX (352) 378-2617.

Exactech, as the manufacturer of this device, does not practice medicine, and is not responsible for recommending the appropriate surgical technique for use on a particular patient. Because this information does not purport to constitute any diagnostic or therapeutic statement with regard to any individual medical case, each patient must be examined and advised individually, and this document does not replace the need for such examination and/or advice in whole or in part. These guidelines are intended to be solely informational and each surgeon must evaluate the appropriateness of these guidelines based on his or her personal medical training and experience. Prior to use of this system, the surgeon should refer to the product package insert for information including, but not limited to, comprehensive warnings, precautions, indications for use, contraindications and adverse effects.

The products discussed herein may be available under different trademarks in different countries. All copyrights, and pending and registered trademarks, are property of Exactech, Inc. **This material is intended for the sole use and benefit of the Exactech sales force and physicians; it is not intended for laypersons.** It should not be redistributed, duplicated or disclosed without the express written consent of Exactech, Inc. ©2023 Exactech, Inc. 00-0002303 Rev.B 0423



**GLOBAL HEADQUARTERS:**  
2320 NW 66TH COURT  
GAINESVILLE, FL 32653 USA

+1 352.377.1140  
+1 800.EXACTECH  
+1 352.378.2617 FAX  
[www.exac.com](http://www.exac.com)